

Declaration of conformity Tank support bolts



NGI fundamentally adheres to all applicable directives and standards. All information is based on the current state of knowledge and is subject to change. We attentively follow the revisions and amendments to these directives and will design our products accordingly. This ensures that products from NGI are always in compliance with currently valid requirements.

Our product category is not covered by the scope of application of the EC directive for machinery. For this reason, they cannot be furnished with the CE marking in accordance with the EC directive for machinery.

Furthermore, we declare that the listed materials applied in our products comply with the demands for materials used within the food and pharmaceutical industries.

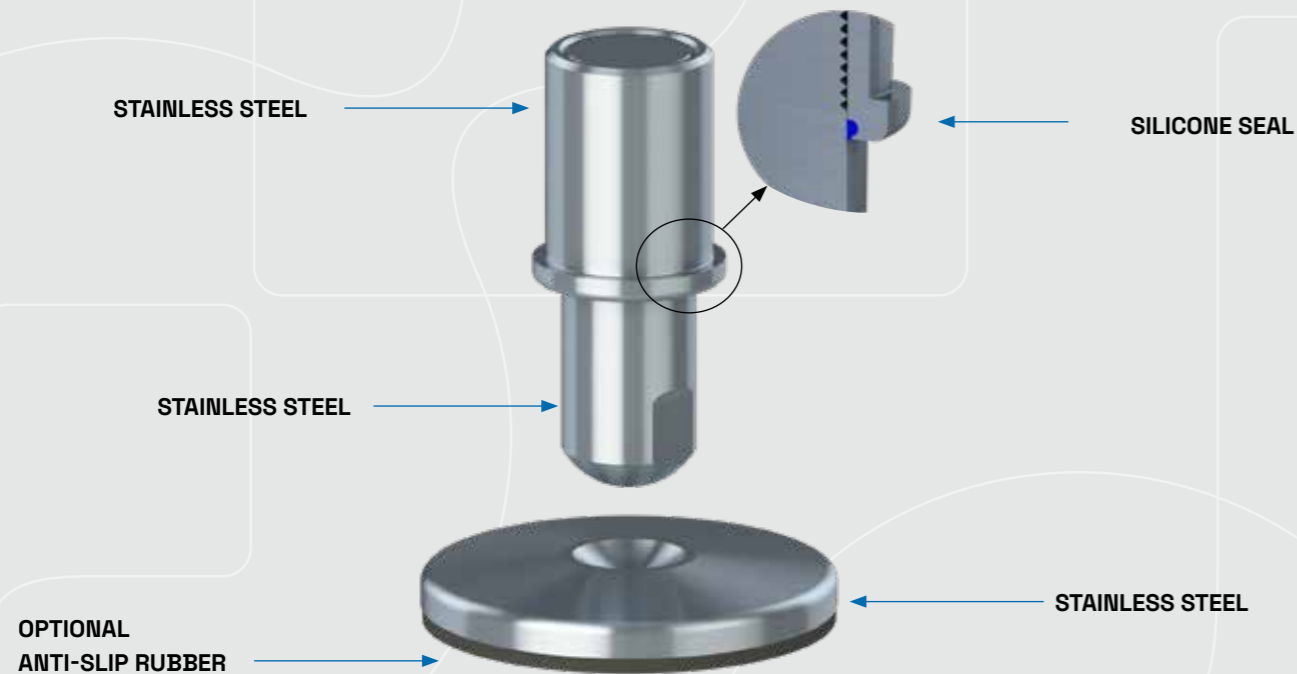

Declaration of conformity Tank support bolts

THE DECLARATION OF MATERIALS CONCERNS THE FOLLOWING APPLICATIONS

Application:

Material type:

Compliance:

Steel spindle and sleeve

Stainless steel, AISI 304/A2 (X5CrNi18-10), Euronorm 1.4301.

By request: Stainless steel, AISI 316/A4 (X 5 CrNiMo 17 12 2), Euronorm 1.4401
EN 10204 Type 2.2. NGI A/S states that the product is in compliance with the order with indication of results of nonspecific inspection.

NGI has got EN 10204 type 3.1 inspection CERTIFIEDs on all material used in the products but not specified for each foot.

In the directive 94/9/EC, Equipment for potentially explosive atmospheres, also known as the ATEX directive, equipment without its own potential source of ignition are not covered, nor shall be marked according to the directive. However, NGI levelling feet are suitable for use in all ATEX zones.

Application:

Material type:

Electrically:

Chemical resistance:

Color:

Hardness:

Range of temperature:

Load:

Anti slip

NBR By request EPDM

Non-conductive

High to commonly applied cleaning agents

Black

Shore A 80 ± 5

Min -20 °C to Max 110 °C

Low load capacity

Application:

Material type:

Electrically:

Chemical resistance:

Color:

Hardness:

Range of temperature:

Storage:

Compliance:

RoHS 2:

Sealing ring between steel components for NGI's machine feet.

Silicon rubber

Non-conductive

High to commonly applied cleaning agents

RAL 5010 (blue)

Shore A 60 ± 5

Min -60°C to Max +200 °C

According to ISO 2230

FDA: Guideline 21 CFR 177.2600

In accordance with the Directive 2011/65/EC OF EUROPEAN PARLIAMENT AND OF THE COUNCIL.

GMP: Good manufacturing process in accordance with 2023/2006 EC.